



# ALR Series Electronic Linear Actuators

## 1 INTRODUCTION

The ALR Series Actuator is designed to replace the OEM equipped shut down solenoid. To properly install the ALR actuator, a precise measurement must be obtained from the removed OEM equipped shutdown solenoid. Before beginning the installation of the ALR actuator, remove all DC battery power from the equipment being serviced.

## 2 APPLICATIONS - ALL MODELS

**NOTE** Check engine dimensions before selecting or installing an ALR as alterations made to factory engines may impact ALR fit.

ENGINE FAMILY	ENGINE MODEL	ACTUATOR MODEL
<b>ISUZU</b>		
C-Series	2CA	ALR190-Y04-12 or -24
	3CA	
	3CB	
	3CD	
	3CE	
L-Series	3LB1	ALR190-I03-12 or -24
	3LD1	
	3LD2	
	4LE1	
	4LE2	
<b>MITSUBISHI</b>		
L-Series	L2E	ALR190-M04-12 or -24
	L3E	
S3L-Series	S3L	
	S3L2	
	S4L	
	S4L2	

ENGINE FAMILY	ENGINE MODEL	ACTUATOR MODEL
<b>FARYMANN</b>		
Farymann	18W	ALR190-F05-12 or -24
<b>KUBOTA</b>		
Super 5 Series	D905	ALR190-K04-12 or -24
	D1005	
	D1105	
	D1105-T	
	V1305	
3300 Series	V3300	
	V3600	
	V3600T	
	V3800	
Kubota	M03	ALR190-KM03-12 or -24
V Series	V2003	ALR190-KV03-12 or -24
	V2203	
	V2403	
	V2607	ALR190-KV07-12 or -24
	V3007	
	V3307	

ENGINE FAMILY	ENGINE MODEL	ACTUATOR MODEL
<b>YANMAR</b>		
TNV- and TNE-Series	2TNV70	ALR190-Y04-12 or -24
	3TNV70	
	3TNV76	
	3TNV82A	
	3TNV84, 84T	
	3TNV88	
	4TNV84	
	4TNV94L	
	4TNV88	
	4TNV98, 98T	
	2TNE	
	3TNE	
4TNE		
<b>PERKINS</b>		
Perkins	404 700	ALR190-P04-12 or -24
	403D-15	ALR190-P403-12 or -24
	N843-C N844L-C N844LT-C	ALR160-S04-12, or -24

## 3 SPECIFICATIONS

<b>ELECTRICAL</b>		
	190-F, 190-I, 190-K, 190-M, 190-P, 190-Y	160-S
Operating Voltage	12 or 24 VDC	12 or 24 VDC
Normal Operating Current	3.2A @12VDC 1.6A @24VDC	4.8A @12 VDC 2.4A @24 VDC
Maximum Current Continuously Rated	5.0A @12VDC 2.5A @24VDC	7.5A @12 VDC 3.8A @24 VDC
Coil Resistance (12VDC) (24VDC)	1.8 ± 0.2 Ω 6.3 ± 0.2 Ω	1.5 ± 0.1 Ω 6.0 ± 0.2 Ω
Connection 16 AWG	( 0.8 mm <sup>2</sup> ) leads	( 0.8 mm <sup>2</sup> ) leads
<b>ENVIRONMENTAL</b>		
Operating Temperature Range	-40°F to +200°F (-40°C to 95°C)	
Relative Humidity	up to 100%	
Vibration	± 4 G, 25 to 100 Hz	
Shock	20 G Peak, 11msec	
All Surface Finishes	Fungus Proof and Corrosion Resistant	
Sealing	Oil, Water, and Dust Resistant	
<b>PHYSICAL</b>		
Weight	1.3 lb (0.59 kg)	

<b>PERFORMANCE</b>		
MODEL	OPERATING STROKE	RESPONSE TIME (1-90%)
160-S	0.51in (13.0mm)	1-12mm 35msec
190-F	0.34in (9.0mm)	1-8mm 35msec
190-I	0.55in (14.0mm)	2-12.6mm 35msec
190-K	0.49in (12.5mm)	1-12mm 35msec
190-M	0.54in (13.9mm)	1-13mm 35msec
190-P	0.42in (10.4mm)	1-9mm 35msec
190-Y	0.34in (9.0mm)	1-8mm 35msec
<b>HARDWARE</b>		
CONNECTOR TYPE	MODELS	
Spade	ALR190-I03	
Packard	ALR160-S04, ALR190-F04, ALR190-I03, ALR190-K04, ALR190-KV03, ALR190-KV07, ALR190-KV3600T, ALR190-M04, ALR190-P04, ALR190-P403, ALR190-Y04	

ALR160-S

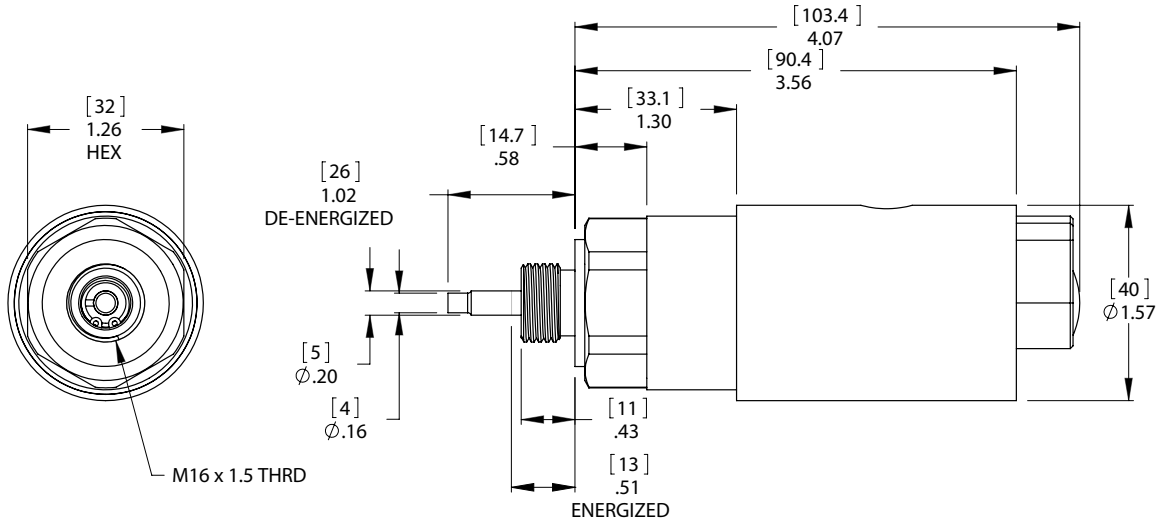

ALR190-P

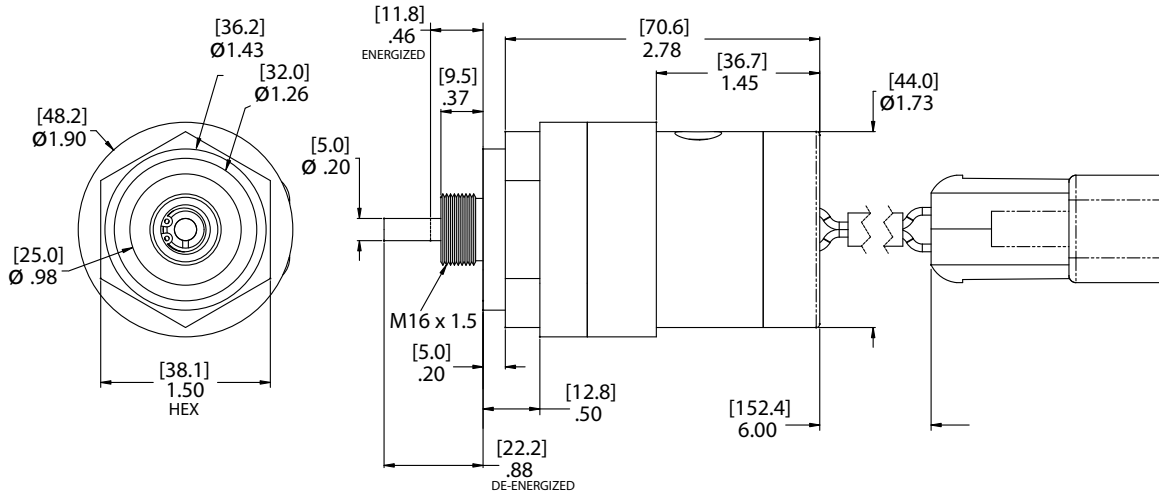

ALR190-I

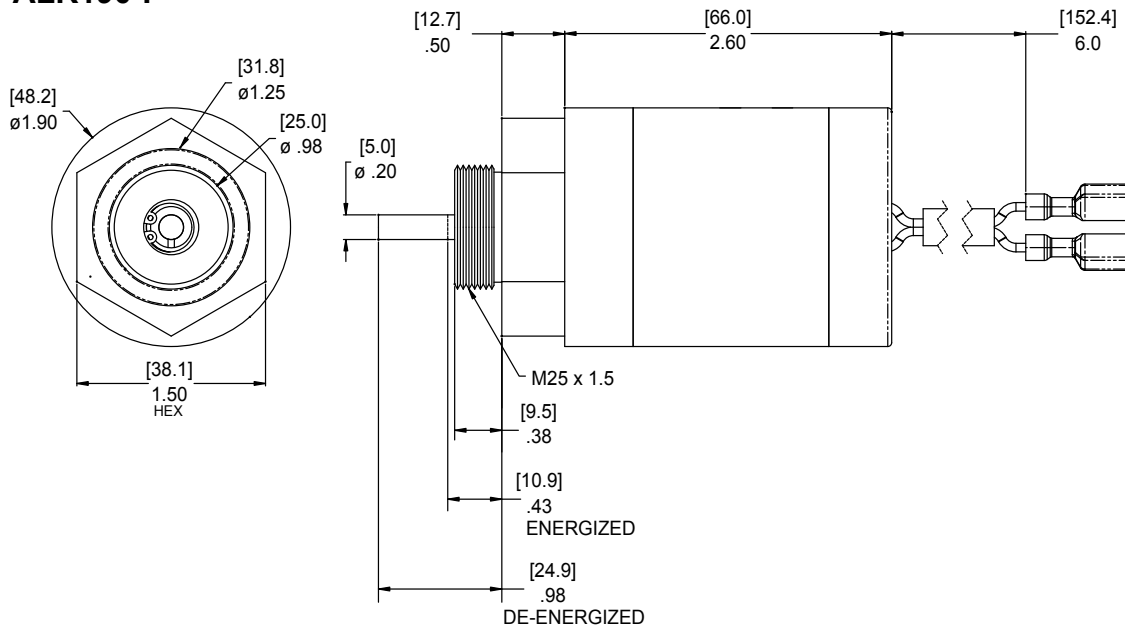

### ALR190-M

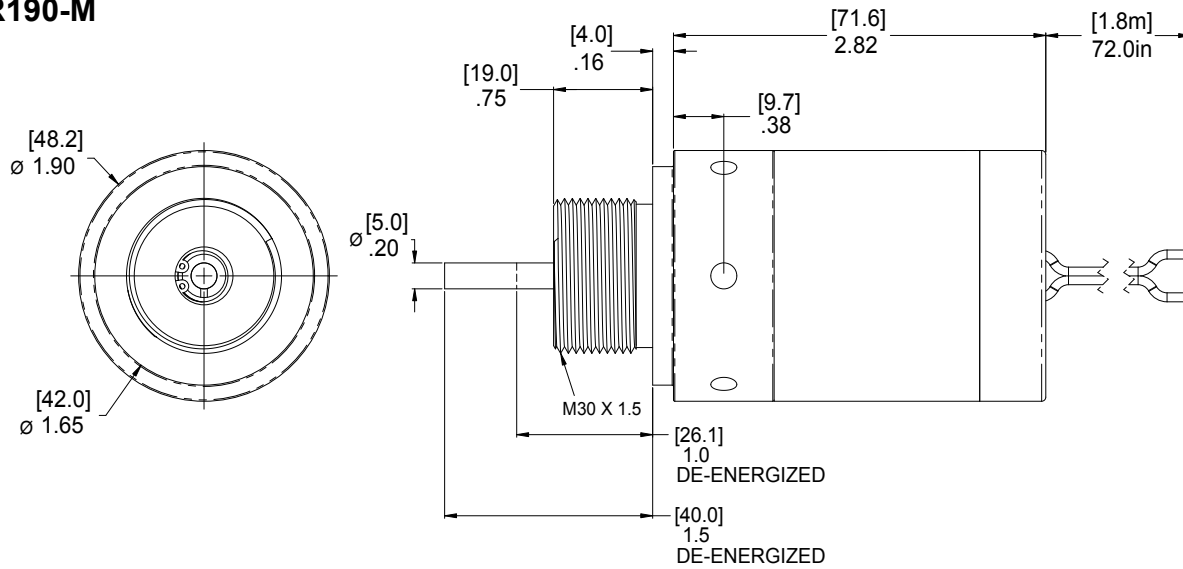

### ALR190-F

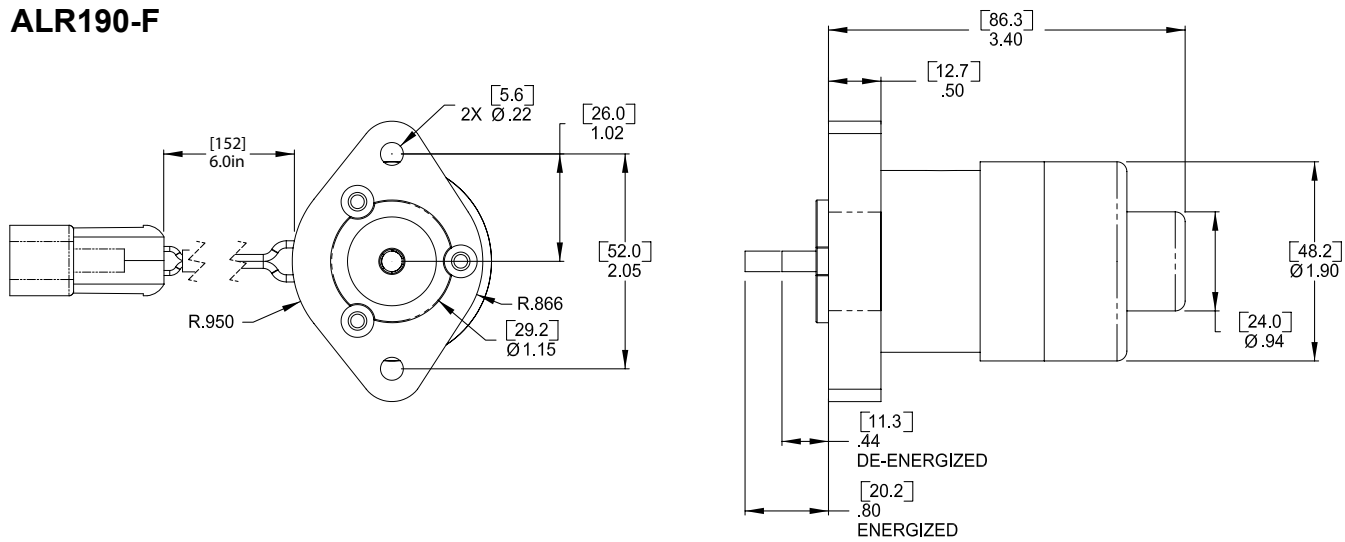

### ALR190-Y

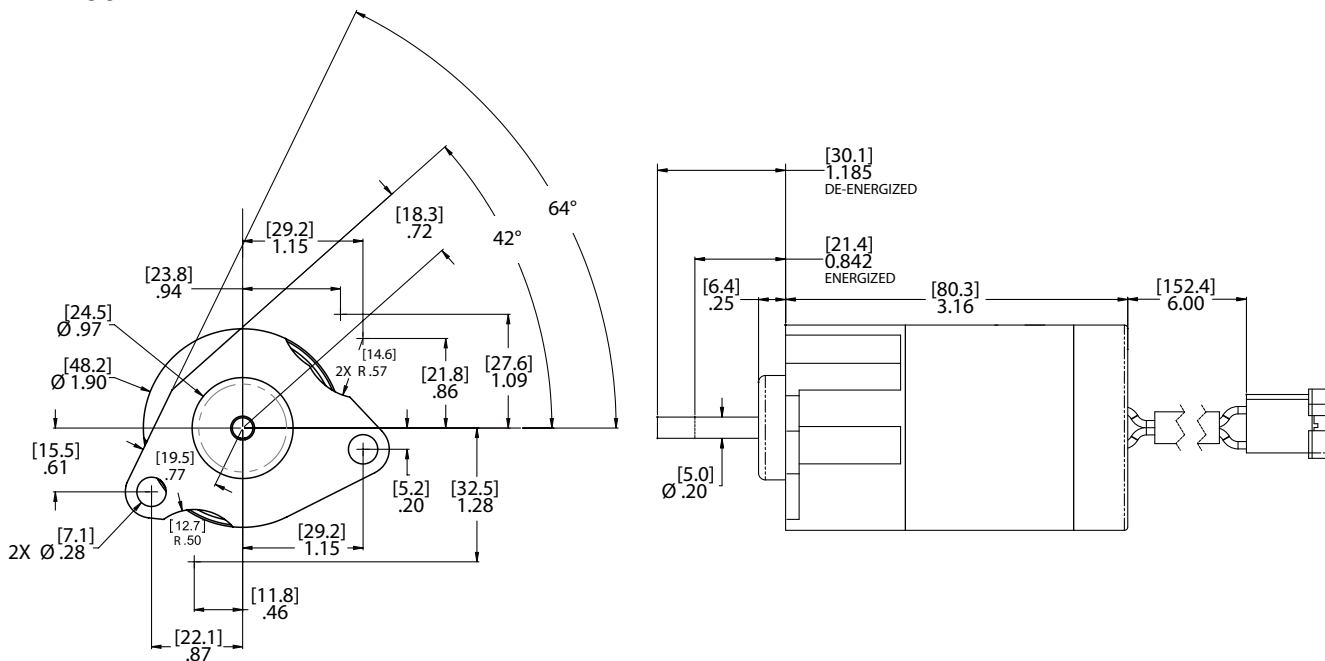

# ALR190-K04

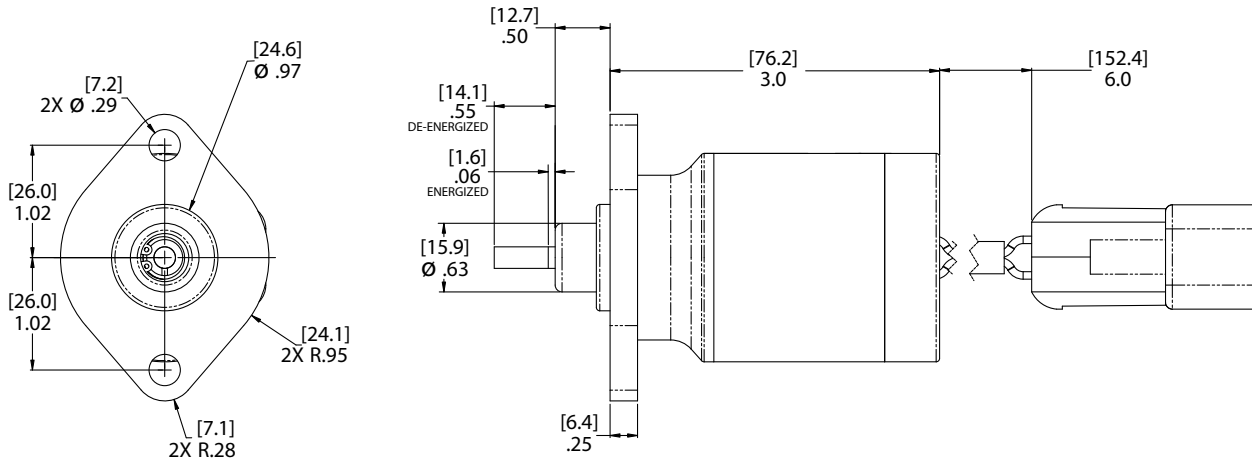

# ALR 190-KM03, ALR 190-KV03, ALR190-KV07

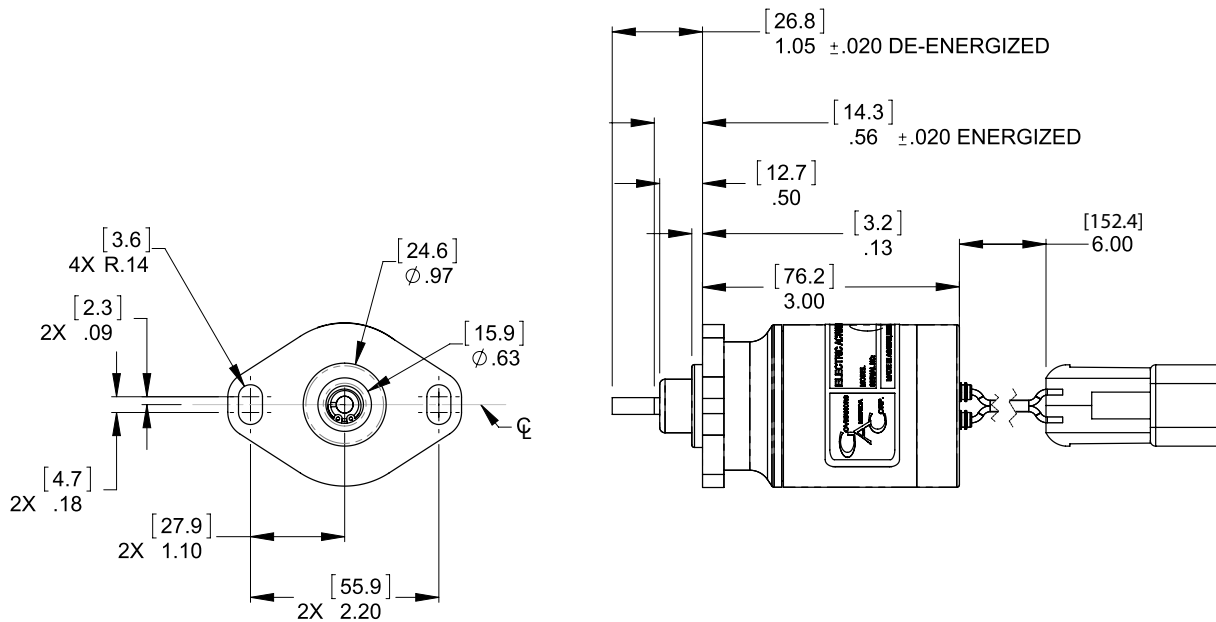

# ALR190-KV3600T

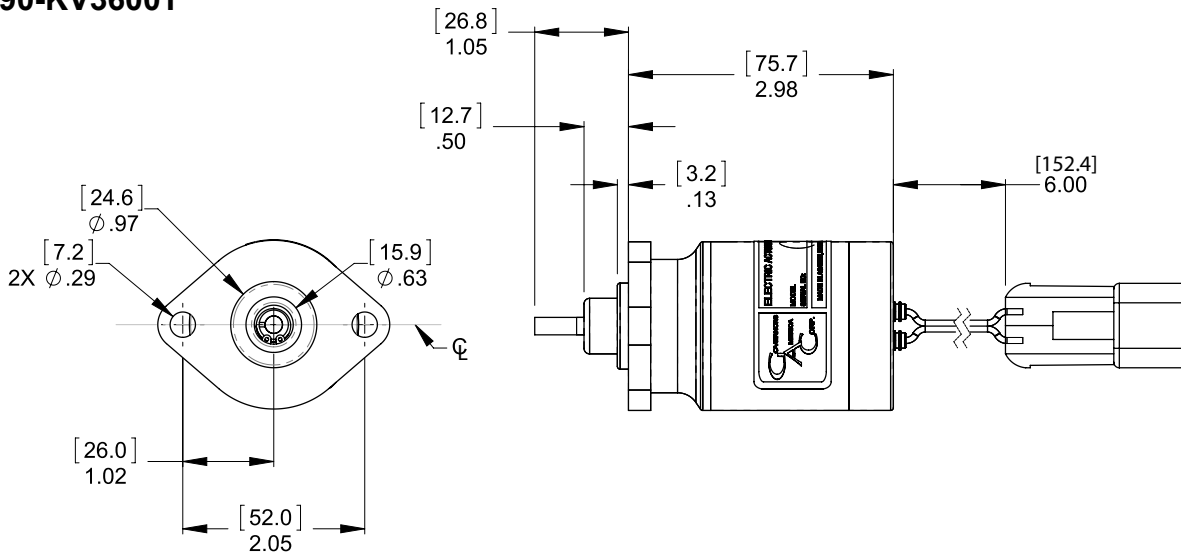

## 5 ALR INSTALLATION INSTRUCTIONS



1. Engine should be equipped with an independent shut down device to prevent overspeed, which can cause equipment damage or personal injury.
2. Do not attempt this installation with engine running or serious damage may occur to the equipment or personnel.

### NOTE

The ALR190-M04 is the only actuator that includes shims.

### INSTALLATION PROCEDURE FOR ALR190-M04



The ALR190-M unit must be adjusted for proper operation. If the installation procedure is not followed, damage to the actuator and or injection pump is possible.

1. Index mark the OEM shutdown solenoid directly behind the locknut with a marker or scribe before loosening the locknut. This mark is important. A precise measurement (depth micrometer) will be taken after shutdown solenoid is removed from the injection pump housing.
2. Remove the wiring harness and loosen the solenoid locknut. Clean the area from dirt or grease. Loosen and remove solenoid from the injection pump housing using standard service cautions.
3. Move locknut on shutdown solenoid back to previously indexed mark (Step 1) and measure distance from the front side of locknut (side that was previously against injection pump housing) to the end of shutdown solenoid shaft. Record this measurement. The more precise this measurement (depth micrometer) the more precise the ALR actuator will perform.
4. Use the locknut from the old shut off solenoid and position it on the new ALR actuator the same distance as the old solenoid (Step 2).  
\*Shims are included with this actuator if needed to set position.
5. Clean threads and mounting surface of the ALR actuator. Install ALR into injection pump housing (no sealant required) until locknut is flush with injection pump housing. If resistance is felt, remove ALR and inspect threads for dirt or burrs. Also use a clean lint free rag to clean injection pump internal threads. A small amount of clean engine oil can be applied if desired. When locknut is flush with injection pump housing tighten nut down.
6. Install wiring harness, start engine, adjust governor speed controller following the GAC manual.

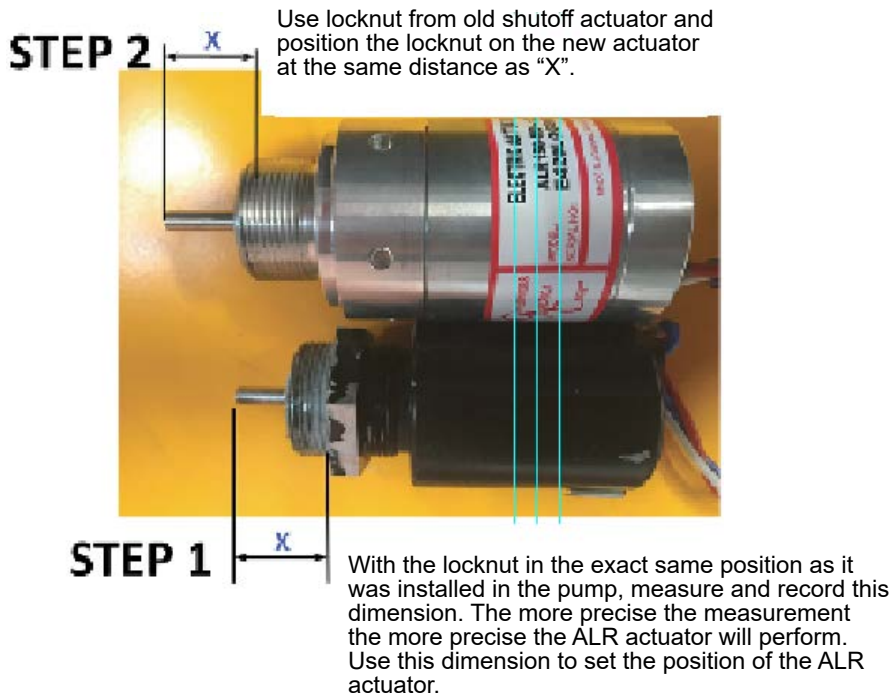

### INSTALLATION PROCEDURE FOR ALR190-I, 190-P AND ALR160-S

1. The actuator is installed in place of the engine's stop solenoid. Remove the solenoid by first disconnecting the electrical leads at the connector.
2. Remove the wiring harness and loosen the solenoid locknut. Clean the area from dirt or grease. Loosen and remove solenoid from the injection pump housing using standard service cautions.
3. Discard OEM installed shutdown solenoid and locknut. Locknut is NOT REQUIRED for the ALR installation.
4. Clean threads and mounting surface of the ALR actuator. Install ALR into injection pump housing (no sealant required) until actuator package is flush with injection pump housing.
  - If resistance is felt, remove ALR and inspect threads for dirt or burrs. Use a clean lint free rag to clean injection pump internal threads. A small amount of clean engine oil can be applied if desired.
  - When actuator is flush with injection pump housing, hand tighten only. After engine has reached operating temperature recheck tightness (use caution, unit will get hot), if required re-tighten by hand only.
5. Install wiring harness, start engine, adjust governor speed controller following the GAC manual.

### INSTALLATION PROCEDURE FOR 190-F, 190-K, 190-Y

1. The actuator is installed in place of the engine's stop solenoid. Remove the solenoid by first disconnecting the electrical leads at the connector.
2. Cover and secure the engine harness leads as they are no longer needed.
3. Remove the two screws that attach the solenoid to the pump face. Save the screws and O-ring. They will be reused when attaching the actuator.
4. Install the o-ring into the counter bore on the pump face.
5. Install the actuator using the solenoid screws.
6. Attach the actuator leads from the speed control unit.

## 6 ALR TROUBLESHOOTING

### TROUBLE SHOOTING

#### If the actuator fails to move to full fuel, make the following tests:

1. Measure battery voltage at the controller (see specification for the operating voltage).
2. Check linkage. Manually operate linkage to ensure it is not sticking or binding.

#### If the actuator fails to move, make the following tests:

1. Measure the coil resistance between the actuator leads (see specification for resistance).
2. Measure the resistance between one lead of the actuator and the housing of the actuator. It should be infinity.
3. Energize the actuator to full fuel by following the procedure in the control unit publication. If the actuator does not move, it is defective.

If problems occur, contact your GAC distributor or GAC Customer Service: [www.governors-america.com](http://www.governors-america.com)